

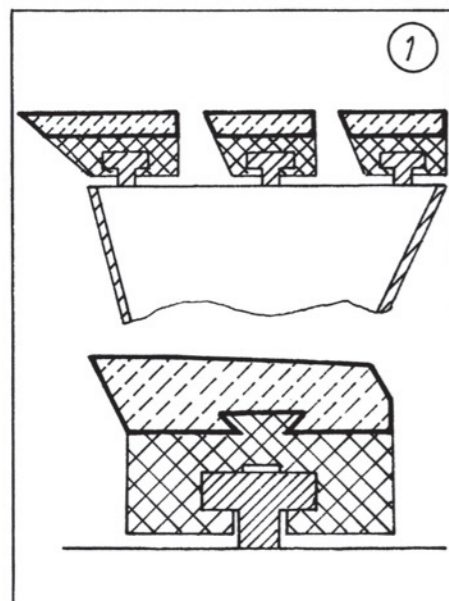

// CERAMIC IN PAPER INDUSTRY

// CERAMIC DEWATERING ELEMENTS FOR PAPER MACHINES AND CONES FOR PAPER INDUSTRY

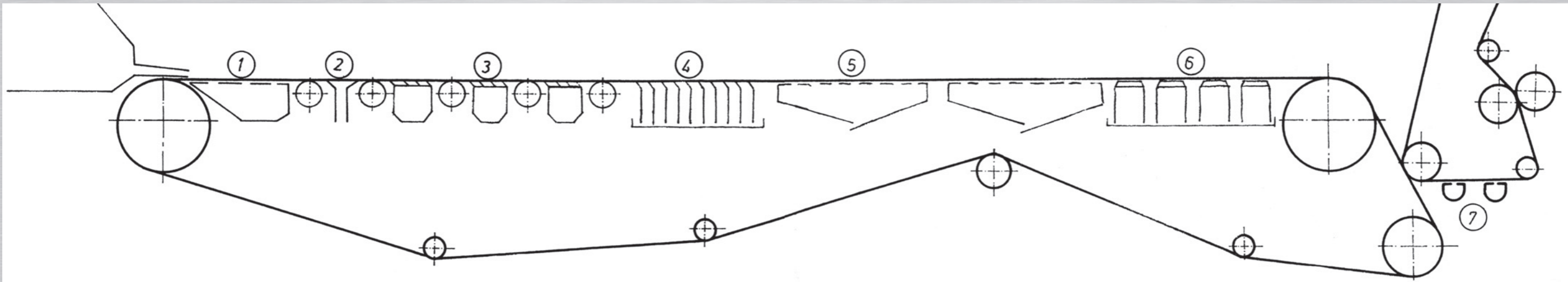

FORMING BOARD

This zone, being exposed to the most severe load conditions, requires extreme wear resistance as well as high-quality finish. By fitting the ceramic foils of high-quality ceramics we get such working elements that maintain their geometry for several years, what is very important for regulation and proper functioning of the machine.

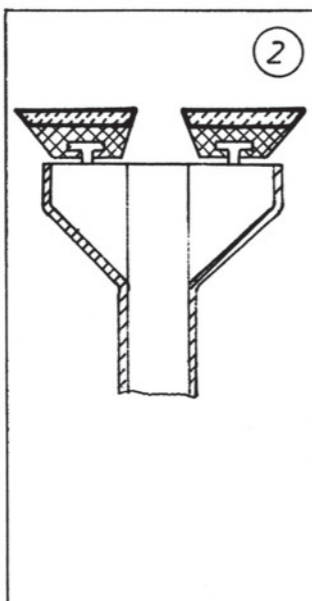

DEFLECTORS

Such design of the foil supports guarantees uniform wire level, efficient direction of the splashy water jet from dewatering rolls, with additional effect of dewatering the deflectors themselves.

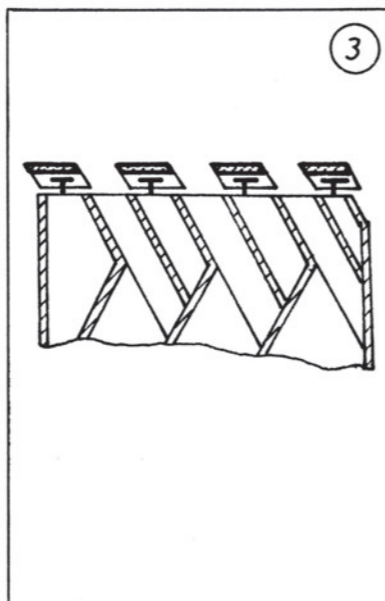

DEWATERING FOILS

With appropriate arrangement and geometrically fully defined working areas, dewatering foils may bring the dewatering diagram close to that theoretically required, while a high wear resistance of ceramic elements insures keeping the given parameters even for several years what, of course, justifies their use. Reduced coefficient of friction, extended wire life, possibility of higher operating speeds, unnecessary adjustments and minimized maintenance requirements are direct elements of production economy.

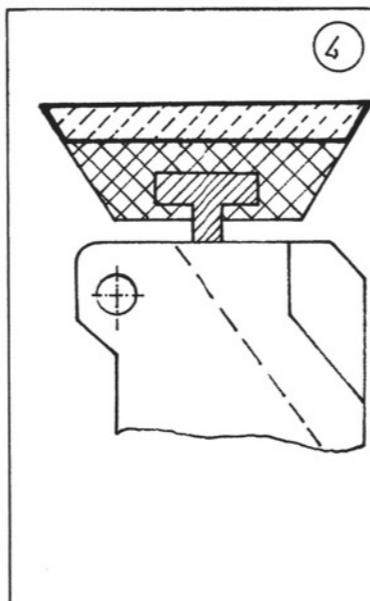

WET SUCTION BOXES

For a good and controlled dewatering an appropriate design of wet suction boxes is of great importance. Design with approx. 50% of open areas with ceramic lined foils (supports) gives the best results. Unchangeable smooth sliding surfaces insure high production economy.

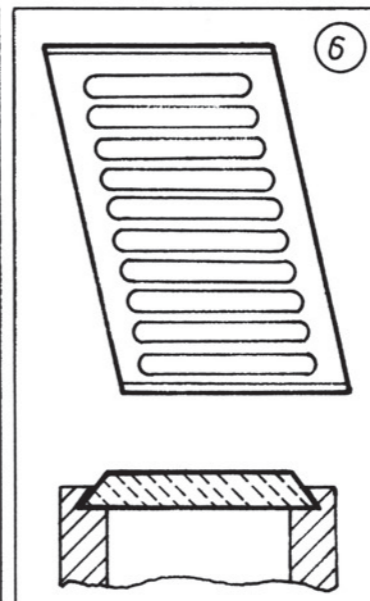

FLAT SUCTION BOXES

Mechanical characteristics of ceramic foils, geometry of working area holes, and arrangement of the boxes on the machine have decisive effects on the productivity, working area (wire foil) lifetime and paper quality. We can say that a design with high-quality ceramic foils is technically unchangeable.

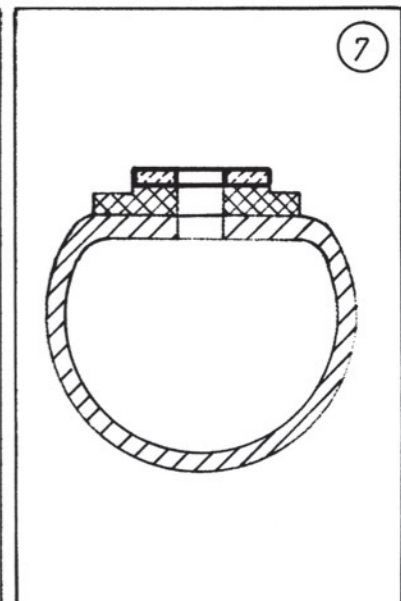

FELT CLEANING SUCTION BOXES

Ceramic foils on the tube-like suction boxes, having smooth surfaces, function properly even for several years without any defects and with negligible felt wear.

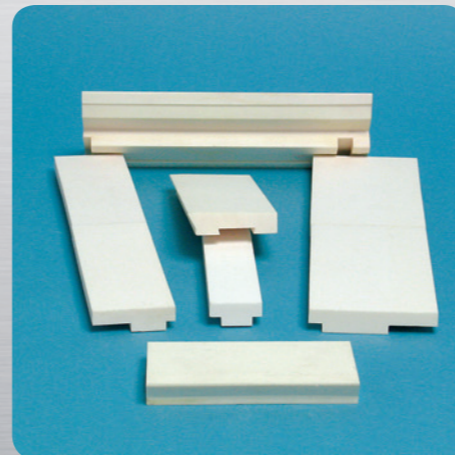
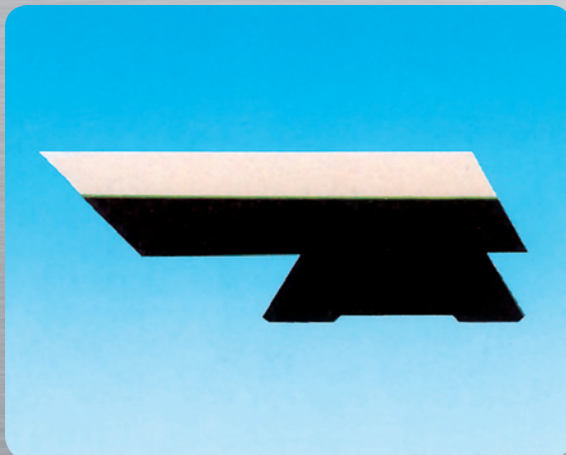

MATERIALS

Materials that are used for production of ceramic elements for paper industry:

- Alumina Oxide 95% Al_2O_3
- Alumina Oxide 99,7% Al_2O_3
- Composite $\text{Al}_2\text{O}_3 + 10\% \text{ZrO}_2$ (Alumina Oxide + Zirconum Oxide)
- Zirconum Oxide ZrO_2

MECHANICAL PROPERTIES

The widest application of ceramics comes from its excellent mechanical properties.

High hardness and wear resistance, modulus of elasticity, comprehensive and flexural strengths have enabled the application of ceramic parts there where high mechanical stresses are experienced.

Such high strength of ceramics is maintained at high temperatures, what makes it an excellent replacement for majority of metals, glasses, plastics, etc.

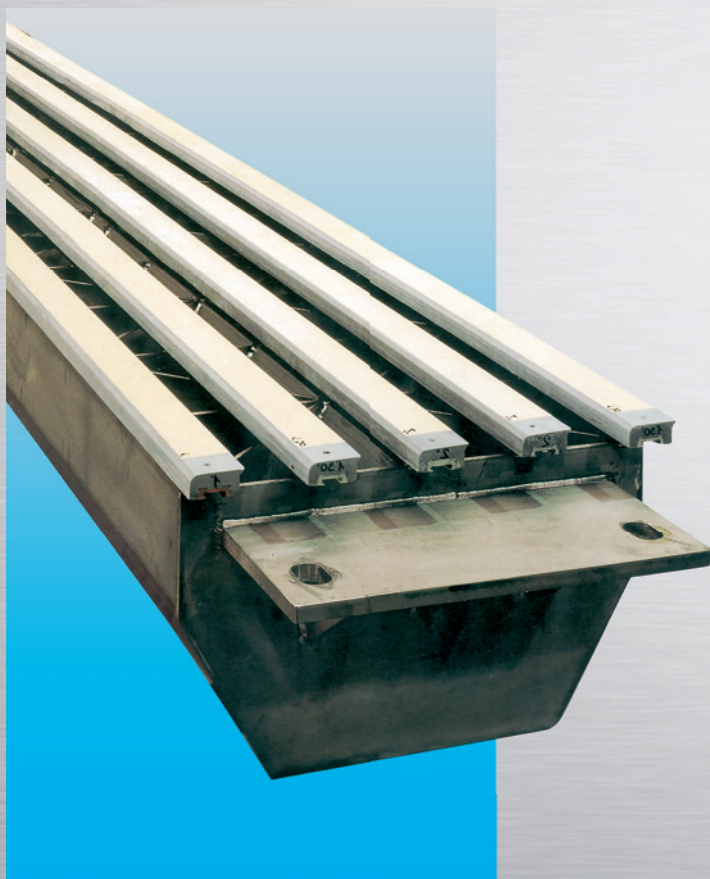
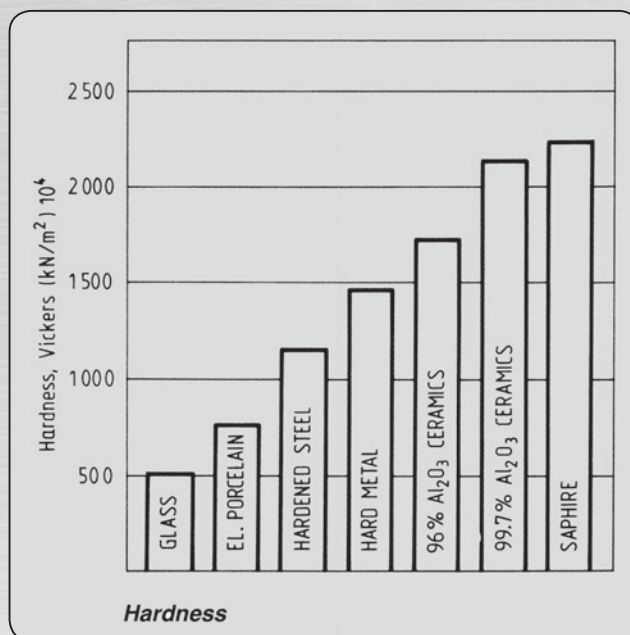

AVTO G d.o.o.
Šlandrova ulica 4, 1231 Ljubljana
Slovenia

T: +386 1 237 3510
F: +386 1 237 3514
E: info@avtog.com

www.avtog.com

